



**CLARK COOPER**  
A DIVISION OF MAGNATROL VALVE CORP.

941 HAMILTON AVENUE  
ROEBLING, NJ 08554

[WWW.CLARKCOOPER.COM](http://WWW.CLARKCOOPER.COM)

## Installation and Operation Manual

**EH40, Version 2017.2**

**Last Updated: 10/9/2017**

### Installation:

The EH40-04, regardless of voltage, may be mounted in any orientation (sideways, upside down, etc.) and will still function per the catalog specifications. AC powered EH40-08's may also be mounted in any orientation. However, DC powered EH40-08's must be mounted vertically with the coil on top in order to open against the catalog differential pressures.

Pipelines or tubing needs to be adequately supported to prevent strains on the valve body connections.

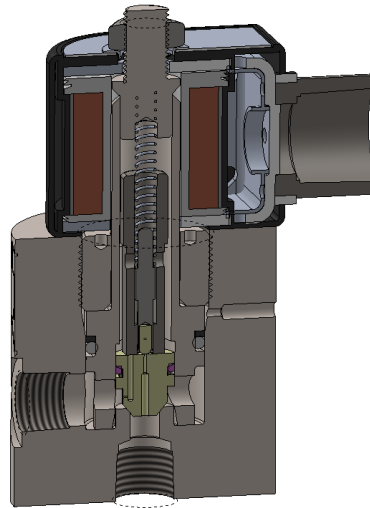

The ¼-18 NPT or ½-14 NPT valve body threads per ANSI/ASME B1.20.1 require a sealant, such as PTFE tape, by design. Follow the sealant manufacturer installation instructions. Some general guidelines are:

- Use 3 to 4 wraps of PTFE tape around the external thread.
- Looking at the external thread, wrap the PTFE tape clockwise. When the threads are turned together, this will eliminate friction trying to unravel the tape.
- Start the tape at least one thread away from the end to eliminate any change of a thread getting in the flow path.
- Do not combine thread sealant and PTFE tape.
- Do not back off a connection simply to adjust orientation. This may destroy the seal.

There is surprisingly no set specification that dictates exact torque values for taper threads. A reputable fitting manufacturer goes as far as to make the statement below.



As a general rule, pipe fittings with tapered threads should not be assembled to a specific torque because the torque required for a reliable joint varies with thread quality, port and fitting materials, sealant used, and other factors. Where many of these factors are well-controlled, such as particular jobs on an assembly floor, a torque range that produces the desired results may be determined by test and used in lieu of turns count for proper joint assembly.

Due to our agreement with this statement, we err on the side of caution and do not publish installation torque values for NPT threads. SAE J1926 fittings, on the other hand, are supplied by various manufacturers who publish installation torques in catalogues. Please follow those installation instructions for use in our 316 stainless steel valve bodies.

It is not recommended to use liquid sealant on the NPT connections. Often, the sealant fluid leaks into the valve and gets deposited on critical areas such as the seat, the pilot orifice, and other areas that inhibit optimal performance and quality sealing.

Make sure that connecting pipes or tubes are clean and free of particulates. Particulates and debris are the most common reason for valves not sealing properly.

Install a filter upstream and close to the solenoid valve (see details in Filter section).

The bonnet tube and piston o-rings of the EH40 are assembled with a small amount of Molykote 111 grease. Additional lubrication is generally not required except during any replacement of worn components. If a valve is cleaned for oxygen service, it will not have any internal components greased.

If the valve has been disassembled for service or cleaning, re-install the bonnet retainer with 23 ft\*lbs of torque using a spanner wrench purchased from Clark Cooper.

#### **Filters:**

Foreign matter such as particulates, rust flakes, PTFE tape, pipe dope, etc., can jam moving parts within a solenoid valve, clog the small orifices, or damage softer sealing surfaces. The result can be a failure to open, close, and seal. A strainer or filter with 200 mesh (0.0029" gaps) or finer is recommended for the EH40 Series products.

The strainer should be placed upstream (inlet side) and as close to the valve as possible. Be sure to select a model that is safe for the inlet pressure. Size the filter so that the pressure drop across it is acceptable for the flow rate.

Built in filters are now being offered.

**Sealing:**

Six different valve seat leakage classifications are defined by ANSI/FCI 91-2-2004. All valves must pass a leakage test prior to the leaving the factory based on the requirements of this specification.

This standard leakage for the EH40 product is Class 2. Class 5 is available.

Class 2 (Allowable Leakage/Min)		
Size	Water (cc)	Air (cc)
0.019	0.01	0.38
0.032	0.01	0.64
0.250	0.10	5.00
0.500	0.20	10.00
0.750	0.30	15.00
1.000	0.40	20.00
1.500	0.60	30.00
2.000	0.80	40.00
2.500	1.00	50.00
3.000	1.20	60.00
4.000	1.60	80.00
6.000	2.40	120.00

Class 5 (Allowable Leakage/Min)		
Size	Water (cc)	Air (cc)
0.019	.1 / 10 Min	0.00
0.032	.1 / 10 Min	0.01
0.250	.1 / 10 Min	0.05
0.500	.1 / 10 Min	0.10
0.750	.1 / 10 Min	0.15
1.000	.1 / 10 Min	0.20
1.500	.1 / 10 Min	0.30
2.000	.1 / 10 Min	0.40
2.500	.1 / 10 Min	0.50
3.000	.1 / 10 Min	0.60
4.000	.1 / 10 Min	0.80
6.000	.1 / 10 Min	1.20

**Electrical:**

Electrical wiring must conform to the nameplate rating. Wiring, conduit, and conduit connections must comply with National and Local Electrical Codes. The standard solenoid enclosure has a ½" NPT conduit connection. Standard lead wires supplied are 18" long, and are wire gauge size 18 AWG minimum. The wire used to connect to the power source should be the same or heavier gauge. Cables extending from ATEX approved coils are 3000mm [118"]. Custom leads lengths may be available upon request.

Unless noted otherwise, all solenoids are designed to operate at  $\pm 10\%$  of the nominal voltage. Check the valve nameplate for specific voltage and amperage requirements. If the ambient and/or fluid temperature is elevated, it is suggested to keep that voltage no higher than nominal to reduce to the risk of burnout (!).

Fuses or circuit breakers are recommended and should be sized according to the inrush amperage and holding amperage requirements of the solenoid.

If the coil is oriented in an inconvenient direction, it may be re-oriented as described in the SAFETY section of this manual. Either coil lead can be hot or neutral.

Standard AC and DC coil wiring:

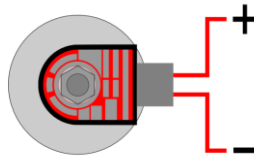

Figure 1. Typical AC and DC coil wiring.

Figure 1 above shows the proper wiring for both AC and DC coils for the EH40 series valves. For DC coils, one lead wire should be connected to the positive terminal and the other lead wire should connect to the negative terminal. For AC coils, one lead wire should connect to the hot terminal and the other lead wire should connect to the neutral terminal. These coils do not have a ground wire. The coil has no polarity so either lead wire from the coil can be the positive lead as both solenoid and valve performance will not be affected.

Optional DC Wiring With Flyback Diode:

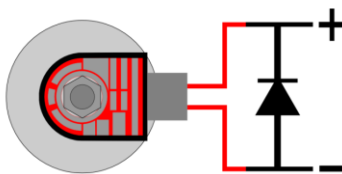

Figure 2. DC coil wiring with flyback diode.

In some systems, it may be useful to install a flyback diode to protect the circuit. The flyback diode prevents sparking between the contacts of the switch that controls power to the DC coil. When the circuit is closed, current flows through the coil and a magnetic field builds inside of the coil winding. Current does not flow through the diode as long as the breakdown voltage of the diode is higher than the voltage across the coil. When the switch is opened, the magnetic field inside of the coil starts to dissipate and in doing so, generates current in the coil and can create a very large negative voltage spike. Because of the large potential, sparks can jump between the contacts of the switch if there is no flyback diode. With the flyback diode, there is still a closed circuit for the current to flow through even though the switch is open. The current will flow through the loop between the diode and the coil until all of the energy is lost and will not spark across the switch.

The UF4001-UF4007 series of diodes may be used as flyback diodes for circuit protection from DC coils. These diodes will handle the low current that is created by the magnetic field after the coil is turned off. Because they are fast acting, the decay time of the flyback current will be relatively shorter compared to other diodes. The table below shows what specific diode should be used for certain coil voltages.

The table of diodes is a suggestion ONLY. The entire circuit should be designed and analyzed by a licensed Professional Electrician or an Electrical Engineer. The Clark Cooper Division of Magnatrol Valve Corporation is not responsible for electrical system damage due to faulty wiring or inadequate protections.

Coil Voltage	Flyback Diode
12V DC	UF4001
24V DC	UF4001
120V DC	UF4004

DIN Connector Option Pin-out:

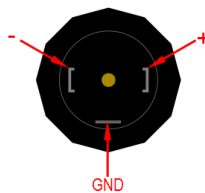

Figure 3. DIN Type A male pinout.



Coils can come with an optional Type A male DIN Connector. The pinout can be seen above. The coil has no polarity so the positive and negative terminals on the DIN connector are interchangeable. The ground pin is not used in these coils.

### **Safety:**

Depressurize a system before trying to remove the valve.

Do not pressurize the valve without the coil installed. While the valve is designed to not burst at pressures approaching four times the rated maximum inlet pressure, the coil actually provides a portion of that inherent strength.

If the wires from the coil need to be directed a certain way, loosen the nut on top of the coil before trying to re-orient. Do not grab any portion of the bonnet tube with a wrench or pliers. Doing so can damage the tube, loosen the retainer causing leakage, or damage an o-ring. The surface temperature of some coils may be >200 degrees Fahrenheit (!) when held in the energized state. Use caution when handling a coil that has just been in use.

### **Troubleshooting:**

1. NEVER attempt to disassemble a valve that is under pressure. This may result in a serious injury or death(!).
2. This valve is designed for use with clean liquids and gases. Install a 100 or 200 mesh filter upstream of the valve to prevent particulates from clogging small orifices in the valve components, inhibiting motion between close fitting parts, or degrading sealing surfaces. Connecting pipes and tubes should be clean prior to installation.
3. 2-4 wraps of PTFE tape must be used with the NPT connections. PTFE tape is preferred over liquid sealants, due to the potential for dripping into the valve. Follow the installation guidelines in our manual to prevent fragments from flowing through the valve and clogging orifices.
4. The solenoid will get hot (>250°F) if held energized or if cycled frequently. Consult Clark Cooper engineering in a situation where there is a hot fluid, hot ambient condition, and high cycling.
5. This valve is only designed to stop fluid from moving in the direction of inlet to outlet. An arrow on the valve body points to the inlet. It will not act as a check valve.
6. All configurations of the EH40-04 may be mounted in any orientation. DC powered EH40-08's must be mounted vertically with the coil on top.
7. Coils are non-polar.
8. Do not exceed the inlet pressure rating on the valve nameplate.



9. If chatter or buzzing is ever noticed on an AC powered valve, remove power and consult Clark Cooper customer service. This could indicate jammed components and could eventually burn out a coil or fatigue sealing surfaces. Chattering components create particulates that lead to further damage.
10. Additional lubrication of the internal components is not required.
11. If the valve has been disassembled for cleaning, re-install the bonnet retainer with 23 ft\*lbs of torque using a spanner wrench purchased from Clark Cooper.
12. If the wires from the coil needs to be directed a certain way, loosen the nut on the top of the coil before trying to re-orient. Do not grab any portion of the bonnet tube with a wrench or pliers.
13. Verify that the power supplied to the solenoid matches the specification that is displayed on the valve nameplate. Valves cannot be converted from DC to AC or AC to DC by simply changing the coil. Valves cannot be converted from AC to DC or visa versa simply by switching coils. Contact Clark Cooper.
14. This valve is designed and tested for use with gases, water, and fluids with viscosity similar to water. Viscous fluids may slow or inhibit operation.
15. No continuity on the lead wires means that the coil is burned out. Replacing the coil may only temporarily cure the symptom, but not the cause. Burnouts can be caused by over-voltaging, long duty cycles in high ambient temperatures, and jammed plungers on AC systems. Consult Clark Cooper engineering.
16. Failure to provide minimum required pressure differential of approximately 50 psi in the EH40 may prevent a normally-closed valve from closing.

### **Solenoid Replacement:**

1. Disconnect the solenoid from the power supply.
2. Remove the top solenoid nut and washer.
3. Remove the solenoid and replace with new one.
4. Replace washer and nut loosely.
5. Position the conduit connection as necessary and tighten the nut just until the wave washer is flat.
6. Reconnect the power supply.

\*\*Visit [clarkcooper.com](http://clarkcooper.com) for product specific assembly videos.