

10 Series Solenoid Coil Manual for EH & EX Series Clark Cooper Solenoid Valves

Issue 2024.1, Released 6/12/24



CLARK COOPER

A DIVISION OF MAGNATROL
VALVE CORP.

941 HAMILTON AVENUE
ROEBLING, NJ 08554

WWW.CLARKCOOPER.COM

P: 856 829 4580

F: 856 829 7303

The Clark Cooper Division of Magnatrol Valve Corporation manufactures solenoid coils of various voltages. This explosion-proof and dust-ignition-proof equipment is intended for use in hazardous locations in accordance with UL-1203:2013 Ed. 5+R:16Oct2018. This equipment meets the requirements for electrical resistance trace heating and heat device sets per CSA C22.2 No. 30:2016 Ed. 4.

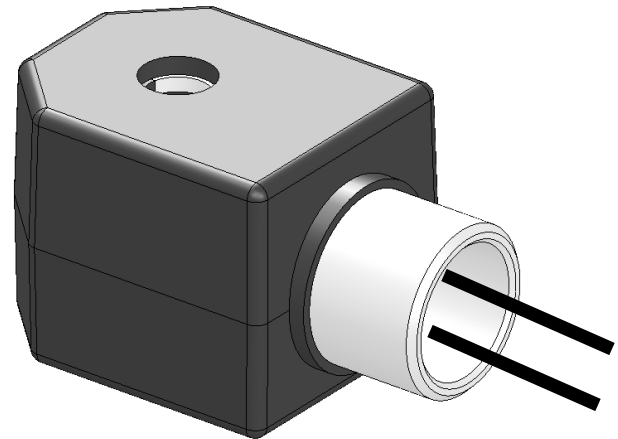

Applications

The 10 Series solenoid coils are designed to be utilized on, but not limited to, the following Clark Cooper solenoid valve product lines: EH30, EH40, EH50, EX30, and EX40. They have been certified by Intertek to achieve the temperature rating codes for the given conditions published in this document. These solenoids are used on valves intended for a wide variety of fluids and gases, both inert and flammable, provided that they are compatible with the wetted materials of valve construction.

The solenoid coils are sized for and rigidly mounted around the Clark Cooper solenoid valve bonnet tubes. No part of the solenoid coil comes in contact with the working fluid or gas.

WARNING
See instructions before installing

Attention
Voir les instructions avant l'installation

Marking

The following information is marked on the top and side solenoid coil surfaces:

- Clark Cooper company logo
- Solenoid coil Clark Cooper part number
- Intertek ETL logo indicating that the component is listing
- Voltage
- Wattage or volt*amps
- Class I, Div 1 &2, Groups A, B, C, D
- Class II, Div 1 & 2, Groups E, F, G
- Operating temp code: T3C or T4 (see Table 1)

Technical Specifications & Certification

This equipment is certified for Class I, Division 1 & 2, Groups A, B, C, & D, and Class II, Divisions 1&2, Groups E, F, and G for the conditions described in Table 1.

The certification applies for a minimum ambient temperature of -4°F [-20 C] for all solenoid coils. The minimum fluid temperature is -423°F.

Voltage	AC/DC	Part Number	Approx Wattage	Resistance, cold (ohm)	Current (amps)	volt*amps	Max Ambient (°F)	Max Fluid (°F)	Operating Temp Code
12	DC	35801704NXX	10	14	0.82	n/a	150	250	T4
24	DC	35801703NXX	10	59	0.41	n/a	150	250	T4
120	DC	35801713NXX	10	1440	0.09	n/a	150	250	T4
12	DC	35801710NXX	22	7.5	1.50	n/a	122	150	T3C
24	DC	35801709NXX	22	29	0.71	n/a	122	150	T3C
120	DC	35801714NXX	22	650	0.19	n/a	122	150	T3C
24	AC	35801702NXX	10	5.5	1.08	25.9	150	250	T4
120	AC	35801701NXX	10	135	0.22	26.4	150	250	T4
240	AC	35801705NXX	10	550	0.10	24.0	150	250	T4
24	AC	35801708NXX	22	3.6	1.86	44.6	122	150	T3C
120	AC	35801707NXX	22	95	0.46	55.2	122	150	T3C
240	AC	35801711NXX	22	364	0.21	50.4	122	150	T3C

Table 1

Installation Instructions:

CAUTION

To reduce risk of ignition of hazardous area, do not remove or service solenoid without disconnecting from the supply circuit and/or while the solenoid valve is under pressure.

mise en garde

Pour réduire le risque d'inflammation d'une zone dangereuse, ne retirez pas ou ne réparez pas le solénoïde sans le débrancher du circuit d'alimentation et / ou pendant que l'électrovanne est sous pression.

All coils have a ½" NPT ANSI/ASME B1.20.1 female conduit connection from which two 18 AWG lead wires protrude. This conduit connection must be properly sealed/bonded per the National Electrical Code (NEC) local rules. Typically, conduit that contains a plug located within several inches is connected. The plug prevents ingress of any potentially flammable gas.

Coil orientation on the valve may be adjusted by first loosening the nut at the top. The coil does not come in contact with the working fluid and is not a pressure boundary component. When the coil is positioned as required, tighten the top nut until the wave washer flattens.

Either lead wire may be line voltage. There is no grounding wire.

Refer to the individual product manuals for solenoid valve usage.

Do not exceed the supply voltage shown on the coil marking.

Construction:

Two factory sealed lead wires of 18 AWG 16/30, 150°C 600V extend from a ½" NPT conduit. Either lead wire may be line voltage. The standard lead wire length is 18", but other lengths may be available upon request. Coils have thermal cutoffs built in. The copper coil and frame is encapsulated in resin molding. The conduit connection is ASTM B633-19 zinc plating on carbon steel. Markings are laser etched.

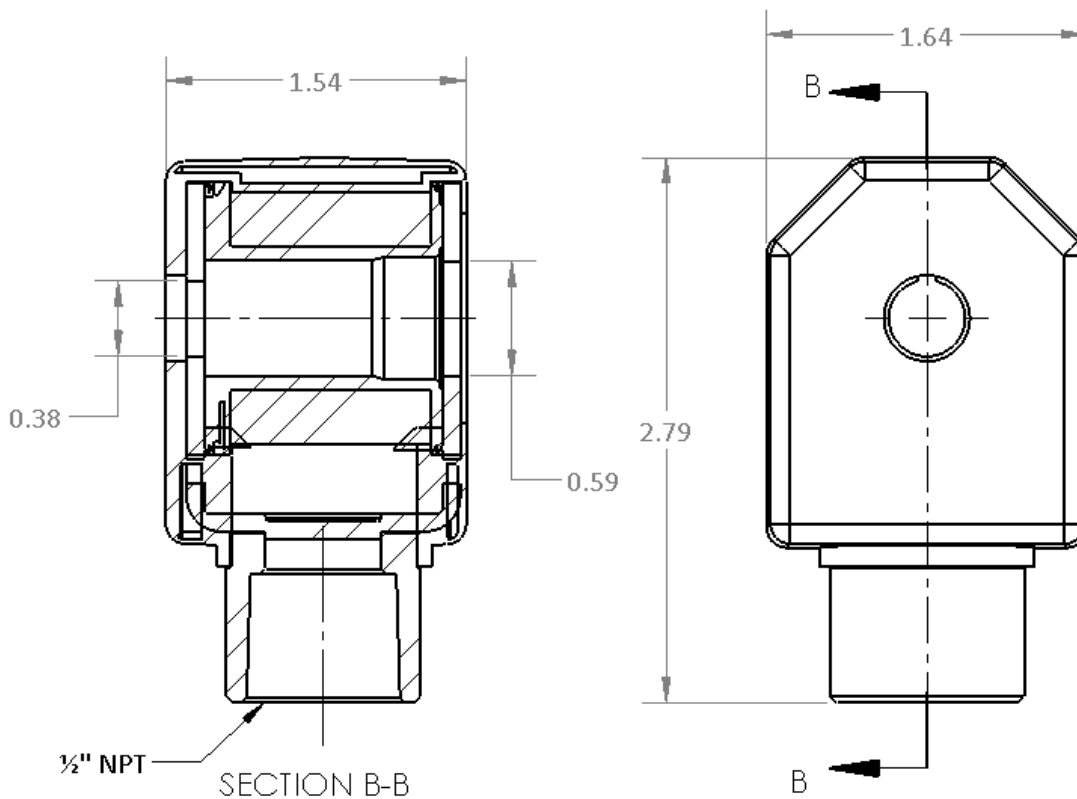

Figure 1 – 10 Series Coil Dimensions

Safety:

- Depressurize a system before trying to remove or partially disassemble any valve. Institute lock out tag out on the coil during maintenance.
- If the cable from the coil needs to be directed a certain way, loosen the nut on top of the coil before trying to position. Do not grab any portion of the bonnet tube with a wrench or pliers.
- When used under the acceptable conditions outlined in this manual, the surface temperature of the high wattage AC coils will approach 300°F if held energized for long periods of time with the maximum allowable fluid and surrounding air temperatures. All coils get hot enough to burn the skin.